



**BALTIMORE  
AIRCOIL COMPANY**



## VXC Evaporative Condensers

### **RIGGING AND INSTALLATION INSTRUCTIONS**





# About rigging and installation

The BAC equipment should be rigged and installed as outlined in this bulletin.

These procedures should be thoroughly reviewed prior to the rigging and operation to acquaint all personnel with the procedures to be followed and to assure that all necessary equipment will be available at the job site. Be sure to have a copy of the unit certified drawing available for reference. If you do not have a copy of this drawing or if you need additional information about this unit, contact the local BAC Balticare representative. His name and phone number can be found on the [www.BaltimoreAircoil.eu](http://www.BaltimoreAircoil.eu). The model type and serial number of your equipment are indicated on the unit nameplate.

## Recommended maintenance and monitoring programme

Checks and adjustments	Start-Up	Weekly	Monthly	Quarterly	Every 6 months	Annually	Shutdown
Cold water basin & strainer	X			X			
Operating level and make-up	X		X				
Blow down	X		X				
Sump heater package	X				X		
Belt tension	X		X				
Drive alignment	X					X	
Locking collar	X				X		
Rotation of fan(s) and pump(s)	X						
Motor voltage and current	X					X	
Unusual noise and/or vibration	X		X				

Inspections and monitoring	Start-Up	Weekly	Monthly	Quarterly	Every 6 months	Annually	Shutdown
General condition	X		X				
Heat transfer section	X				X		
Drift eliminators	X				X		
Water distribution	X				X		
Fan shaft	X			X			
Fan motor	X			X			
Spray water pump	X			X			
Electric water level control package (optional)	X				X		
TAB test (dip slides)	X	X					
Circulating water quality	X		X				
System overview	X					X	
Record keeping	as per event						

Lubrication	Start-Up	Weekly	Monthly	Quarterly	Every 6 months	Annually	Shutdown
Fan shaft bearings	X				X		X
Motor bearings*	X				X		
Adjustable motor base	X				X		X
Hinges & access door bolts						X	

\* only for motors with grease fittings with typical frame size > 200L (>30 KW)

Cleaning procedures	Start-Up	Weekly	Monthly	Quarterly	Every 6 months	Annually	Shutdown
Mechanical cleaning	X					X	X
Disinfection**	(X)					(X)	(X)
Drain basin and pump							X

\*\* depends on applied code of practice

## Notes

1. Water treatment and auxiliary equipment integrated in the cooling system may require additions to the table above. Contact suppliers for recommended actions and their required frequency.
2. Recommended service intervals are for typical installations. Different environmental conditions may dictate more frequent servicing.
3. When operating in ambient temperatures below freezing, the unit should be inspected more frequently (see Cold weather operations in the appropriate Operating and Maintenance Instructions).
4. For units with belt drive, tension on new belts must be readjusted after the first 24 hours of operation and monthly thereafter.



# Table of contents

## RIGGING AND INSTALLATION INSTRUCTIONS

<b>1</b>	<b>General information</b>	<b>5</b>
	About engineering and application practices	5
	Shipping	5
	Inspection before rigging	5
	Unit weights	7
	Anchoring	7
	Leveling	7
	Electrical connections	8
	Connecting pipework	8
	Coil connections	8
	Purge requirements	9
	Freeze protection	9
	Bleed Line Installation	9
	Safety Precautions	10
	Non-walking surfaces	12
	Modifications by others	12
	Warranty	12
<b>2</b>	<b>Rigging</b>	<b>13</b>
	General notes	13
	Rigging method lower section	16
	Rigging method upper section	17
<b>3</b>	<b>Section assembly</b>	<b>18</b>
	Method	18
<b>4</b>	<b>Optional accessories assembly</b>	<b>22</b>
	General	22
	Placement of Steel Eliminators	23
	Clean out port	23
<b>5</b>	<b>Inspection prior to start-up</b>	<b>25</b>
	General	25
<b>6</b>	<b>Further Assistance &amp; Information</b>	<b>26</b>
	Assistance	26
	More information	26



# VXC GENERAL INFORMATION

## About engineering and application practices

This bulletin only refers to the assembly of the unit. To ensure a proper operation, a correct integration of the unit in the overall installation is mandatory. For good engineering and application practices on layout, levelling, connecting pipework, etc., please refer to our website:  
<http://www.baltimoreaircoil.eu/knowledge-center/application-information>.

## Shipping

BAC cooling equipment is factory assembled to assure uniform quality and minimum field assembly. The models VXC 14, VXC 18, VXC 36, and VXC 45 are shipped in one single section. All other models are shipped in two sections (upper and lower) due to shipping height restrictions.



### CAUTION

**Do not cover units with PVC eliminators or fill with a plastic tarpaulin.  
Temperature increase due to sun radiation could deform the fill or eliminators.**

## Inspection before rigging

When the unit is delivered to the job site, it should be checked thoroughly to ensure all required items have been received and are free of any shipping damage prior to signing the bill of lading.

The following parts should be inspected:

- Sheaves and belts
- Bearings
- Bearing supports
- Fan motors
- Fan wheels and shafts
- Coils
- Water distribution system
- Strainers
- Float valve assembly
- Spray pump
- Eliminators
- Interior surfaces

- Exterior surfaces
- Miscellaneous items

An envelope with check-list is stored in a wooden no nail crate or a plastic container which is placed in the lower section. For safety reasons, access doors / panels may be sealed with bolts. The following table specifies which wrench is required to open them.

Wrench to open access door	Wrench to open access panel
17 mm	14 mm (for air inlet screen: 10 mm)

*Required wrenches to open access door/panel*

The wooden no nail crate / plastic container also contains miscellaneous parts such as gasket, hardware and accessory items.

At temperatures below -10°C the butyl sealer tape might lose its flexibility. We recommend to store the sealer tape in a heated room before using it during rigging at freezing temperatures.



**CAUTION**

**Be sure to remove all miscellaneous items from the pan before the unit is assembled.**

The hardware is packed in a plastic container and located inside the lower section of the unit. For models VXC 14 up to 205, see picture below.



*Hardware location*

For models VXC 221 up to 1608, and VXC-C, the plastic container is fixed to the bearing support at the air intake side.

If the pump is shipped loose, it is packed in a wooden box, also located at the air intake side and fixed with straps on a special skid.



Location hardware and pump

1. Hardware
2. Pump (if shipped loose)

## Unit weights

Before rigging any BAC equipment, the weight of each section should be verified on the unit certified drawing.



These weights are **approximate** and should be confirmed by weighing **before lifting** when available hoisting capacity provides little margin for safety.



### CAUTION

**Before an actual lift is undertaken, ensure no water, snow, ice or debris has collected in the sump or elsewhere in or on the unit. Such accumulations will add substantially to the equipment's lifting weight.**

In the event of extended lifts or where hazards exist, the lifting devices should be used in conjunction with safety slings placed under the unit.

## Anchoring

The unit must be properly anchored in place.

Refer to the suggested support details on the certified drawing for locations of the mounting holes. Anchor bolts must be provided by others.

Holes suitable for 20 mm bolts are provided in the bottom flange of the lower section for bolting the unit to the support beams.

## Leveling

The unit must be level for proper operation and ease of piping.

Support beams must also be level as shims should not be used between pan and support beams to level the unit.

## Electrical connections

The units are delivered with a number of electrical components that need to be connected after rigging. For all electrical components, please refer to the specific wiring diagrams in the submittal package.

It might be necessary to remove the belts and move the motor to another position to allow connection of the electrical cables to the motor. (See Belt Tensioning and Drive Alignment sections in the Rigging and installation instructions for more detailed information.)

## Connecting pipework

All piping external to BAC cooling equipment must be supported separately.

In case the equipment is installed on vibration rails or springs, the piping must contain compensators to eliminate vibrations carried through the external pipework.

Suction pipe sizing should be done according to good practice, which may for larger flows require larger pipe diameters than the outlet connection. In such cases adapter pieces need to be installed.

## Coil connections

Hot dip galvanized and stainless steel coils of BAC condensers are filled with a low pressure inert gas at the factory before shipping, to ensure an optimal internal corrosion protection. It is recommended to check the overpressure every six months (connect a manometer to the valve).

On site, the pressure needs to be released from the coil. Remove the plug first before opening the pressure relieve valve.

In case of threaded connections, clean up the thread prior to connecting it to the pipework.

Non-threaded connections must be bevelled on site before they can be welded.



*Upper coil connection with pressure release valve on condensers.*



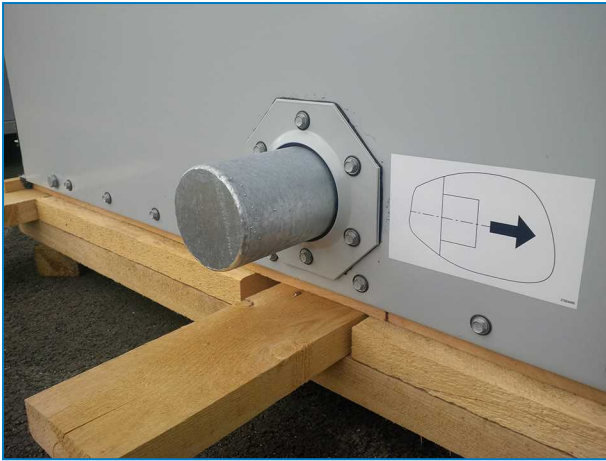

Lower closed-off coil connection on evaporative condensers.



### CAUTION

**Once the coil is no longer protected by the inert gas, proper actions against corrosion must be taken on site.**

## Purge requirements

The installer of BAC condensers must ensure proper air purging of the system prior to operation. Entrained air can obstruct free drainage of refrigerant and reduce condensing capacity, resulting in higher operating pressures than designed.

All connections (installed by others) must be leak free and tested accordingly.

To verify absence of non condensables in the refrigeration system, follow the instructions in the BAC Application Handbook – EU Edition (<https://www.baltimoreaircoil.eu/en/downloads/pdf-Application-Handbook-EU-Edition>), Section "Condenser Engineering Guidelines".

## Freeze protection

These products must be protected against damage and/or reduced effectiveness due to possible freeze-up by mechanical and operational methods. Please contact your local BAC Balticare representative for recommended protection alternatives.

## Bleed Line Installation

Evaporative condensers that are furnished with a factory installed circulating pump include a bleed line with valve.

On units operating with a remote sump tank, install a bleed line with valve between the system circulating pump discharge riser and a convenient drain. Locate the bleed line in a portion of the riser piping that drains when the pump is off.

The bleed valve should always be open when the unit is in operation, unless the bleed rate is automatically controlled by a water treatment system.



# Safety Precautions

All electrical, mechanical and rotating machinery constitutes a potential hazard, particularly for those not familiar with its design, construction and operation. Accordingly, adequate safeguards (including use of protective enclosures where necessary) should be taken with this equipment both to safeguard the public (including minors) from injury and to prevent damage to the equipment, its associated system and the premises.

If there is doubt about safe and proper rigging, installation, operation or maintenance procedures, contact the equipment manufacturer or his representative for advice.

When working on operating equipment, be aware that some parts may have an elevated temperature. Any operations on elevated level have to be executed with extra care to prevent accidents.

## AUTHORIZED PERSONNEL

The operation, maintenance and repair of this equipment should be undertaken only by personnel authorized and qualified to do so. All such personnel should be thoroughly familiar with the equipment, the associated systems and controls and the procedures set forth in this and other relevant manuals. Proper care, personal protective equipment, procedures and tools must be used in handling, lifting, installing, operating, maintaining and repairing this equipment to prevent personal injury and/or property damage. Personnel must use personal protective equipment where necessary (gloves, ear plugs, etc...)

## MECHANICAL SAFETY

Mechanical safety of the equipment is in accordance with the requirements of the EU machinery directive. Depending upon site conditions it also may be necessary to install items such as bottom screens, ladders, safety cages, stairways, access platforms, handrails and toe boards for the safety and convenience of the authorized service and maintenance personnel.

At no time this equipment should be operated without all fan screens, access panels and access doors in place. When the equipment is operated with a variable fan speed control device, steps must be taken to avoid operating at or near to the fan's «critical speed».

For more information consult your local BAC Balticare representative.

## ELECTRICAL SAFETY

All electrical components associated with this equipment should be installed with a lockable disconnect switch located within sight of the equipment.

In the event of multiple components, these can be installed after a single disconnect switch but multiple switches or a combination thereof are also allowed.

No service work should be performed on or near electrical components unless adequate safety measures are taken. These include, but are not limited to the following:

- Isolate the component electrically
- Lock the isolation switch in order to prevent unintentional restart
- Measure that no electrical voltage is present anymore
- If parts of the installation remain energized, make sure to properly demarcate these in order to avoid confusion

Fan motor terminals and connections may have residual voltage after unit shut-down. Wait five minutes after disconnecting the voltage at all poles before opening the fan motor terminal box.



### CAUTION

**Failure to use designated lifting points can result in a dropped load causing severe injury, death and/or property damage. Lifts must be performed by qualified riggers following BAC published Rigging Instructions and generally accepted lifting practices. The use of supplemental safety slings may also be required if the lift circumstances warrant its use, as determined by the rigging contractor.**

## LOCATION

All cooling equipment should be located as far away as possible from occupied areas, open windows or air intakes to buildings.



### CAUTION

**Each unit must be located and positioned to prevent the introduction of discharge air into the ventilation systems of the building on which the unit is located and of adjacent buildings.**



For detailed recommendations on BAC equipment layout, please see the BAC Application Handbook EU-Edition, the BAC website [www.BaltimoreAircoil.eu](http://www.BaltimoreAircoil.eu) or contact your local BAC-Balticare Representative.

Standard units are installed on 2 I-beams, directly on the concrete floor as indicated in the figure below. If units are installed on a steel structure above ground level, several precautions must be considered.

1. If the unit is installed more than 300 mm above ground level, it is necessary for safety reasons to install a solid bottom panel to provide protection from moving parts e.g. sheaves, belts, motors, fan wheels, shafts, ...
2. This solid bottom is also required to ensure that intake air is drawn horizontally into the cooling tower and not from the bottom. If bottom air is drawn in into the unit, a reduction in air resistance to the fans occurs; resulting in higher air flow hence increased absorbed motor power. To avoid fan motor overload in these cases, a reduction of fan speed is required (change motor sheave) to obtain normal motor current and airflow. For more information, please refer to the section "Application Guidelines, Location" in the Application Handbook EU - Edition. (<http://www.baltimoreaircoil.eu/knowledge-center/application-information>)

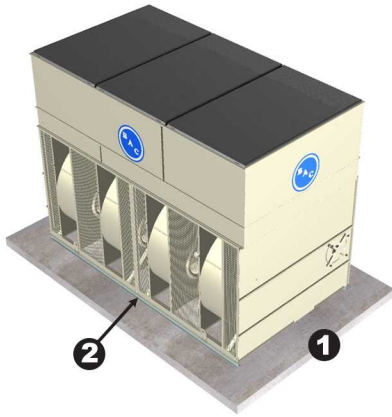

Unit mounted directly on the concrete floor

1. Concrete floor
2. Mounted directly onto the concrete floor, thus closing off open bottom of unit

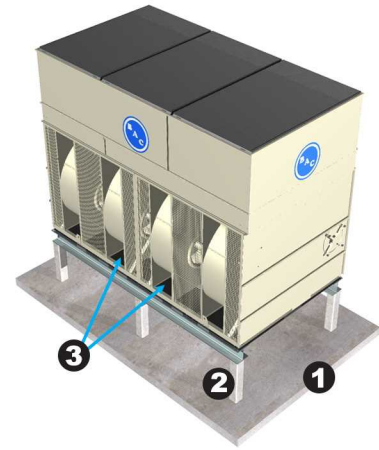

Unit installed on elevated steel structure

1. Concrete ground floor
2. Elevated steel structure
3. Solid bottom panel

## LOCAL REGULATIONS

Installation and operation of cooling equipment may be subject to local regulations, such as establishment of risk analysis. Ensure regulatory requirements are consistently met.

## Non-walking surfaces

Access to and maintenance of any component needs to be performed in accordance with all local applicable laws and regulations. If the proper and required access means are not present, temporary structures need to be foreseen. Under no circumstance can one use parts of the unit, that are not designed as an access mean, unless measures can be taken to mitigate any risks that might occur from doing so.

## Modifications by others

Whenever modifications or changes are made by others to the BAC equipment without written permission of BAC, the party who has done the modification becomes responsible for all consequences of this change and BAC declines all liability for the product.

## Warranty

BAC will guarantee all products to be free from manufactured defects in materials and workmanship for a period of 24 months from the date of shipment. In the event of any such defect, BAC will repair or provide a replacement. For more details, please refer to the Limitation of Warranties applicable to and in effect at the time of the sale/purchase of these products. You can find these terms and conditions on the reverse side of your order acknowledgement form and your invoice.

## General notes

1. Unless unit ships fully assembled, unit must be rigged one section at the time.
2. If the delivery consists of separate sections, do not assemble before lifting, as the lifting devices provided are not designed to support the weight of the entire assembly.



### CAUTION

**When the unit is installed, all metal parts created by drilling, fastening self tapping screws, grinding, welding or other mechanical works must be removed from the unit. If they remain on the unit (typically on the double break flanges) this could lead to corrosion and eventually coating damage.**

3. Spreader bars of the full width of the section must be used between the lifting cables to prevent damage to the section.
4. For extended lifts or where hazards exist, it is recommended to use the lifting devices in conjunction with safety slings placed under the unit.
5. The proper rigging sequence for units is to lift the lower section into place, apply sealer to the pan where the upper section will be located (See "Section assembly" on page 18) and then lift the upper section into place.
6. If the (pump) piping from coil products is split for transport reasons, the piping must be assembled on site by means of a flexible connection (typically a rubber sleeve or coupling).
7. Lifting devices have been provided on all sections. The table below gives the preferred method for rigging each section of a unit.
8. For asymmetrical load distribution shorten the slings at one end so the casing is approximately horizontal.

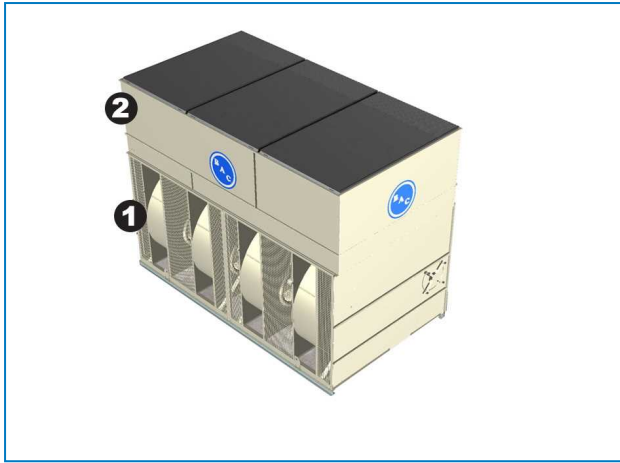

Unit sections

1. Lower section
2. Upper section

Model	Lower section					Upper section				Discharge accessories <sup>1</sup>		Sealing method
	N° of lower sections	N° of upper sections	Rigging method	Spreader bar length (mm)	Min. "H" (mm)	Rigging method	Spreader bar length (mm)	Min. "H" (mm)	Steel eliminator placement	Rigging method <sup>2</sup>	Min. "H" (mm)	
VXC-14, 18, 36, 45	FULLY ASSEMBLED		B	1092	3658	-	-	-	M	H	2438	-
VXC-25, 28, 52 through 65	1	1	C	1219	3658	H	-	2438	M	H	2438	I
VXC-72 through 135	1	1	C	1219	3658	G	1092	3658	M	H	3658	I
VXC-150 through 205	1	1	C	1473	3658	G	1473	3658	M	H	3658	I
VXC-C 220 through C 287	1	1	C	2286	3700	G	2007	3700	M	H	3700	I
VXC-C 325 through C 426	1	1	C	2286	5000	G	2007	5000	M	H	5000	I
VXC-221 through 265	1	1	C	2438	3658	G	2007	3658	M	H	3658	I
VXC-S288 through S350	1	1	C	2450	3700	G	2450	4300	M	H	4300	I
VXC-S403 through S504	1	1	C	2450	5000	G	2450	5500	M	H	5500	I

Model	N° of lower sections	N° of upper sections	Lower section				Upper section				Discharge accessories <sup>1</sup>		Sealing method
			Rigging method	Spreader bar length (mm)	Min. "H" (mm)	Rigging method	Spreader bar length (mm)	Min. "H" (mm)	Steel eliminator placement	Rigging method <sup>2</sup>	Min. "H" (mm)		
VXC-S576 through S700	1	2	C	2450	6000	G	2450	4300	M	H	4300	J	
VXC-S806 through S1010	1	2	D	2450	6700	G	2450	5500	M	H	5500	J	
VXC-357 through 454	1	1	C	3050	3700	G	3050	4300	M	H	4300	I	
VXC-562 through 680	1	1	C	3050	5000	G	3050	5500	M	H	5500	I	
VXC-714, 798, 908	1	2	C	3050	6000	G	3050	4300	M	H	4300	J	
VXC-1124, 1240, 1360	1	2	D	3050	6700	G	3050	5500	M	H	5500	J	
VXC-495 & 516	1	1	C	3650	4300	G	3650	4300	M	H	4300	I	
VXC-715, 772, 804	1	1	C	3650	5500	G	3650	5500	M	H	5500	I	
VXC-990 & 1032	1	2	C	3650	6700	G	3650	4300	M	H	4300	J	
VXC-1430 through 1608	1	2	D	3650	6700	G	3650	5500	M	H	5500	J	

*Rigging method, discharge accessory rigging method and optional steel eliminator placement indication*

<sup>1</sup> Discharge accessories can be: plume abatement coil, positive closure damper, tapered discharge hood, sound attenuation.

<sup>2</sup> For asymmetrical load distribution (with external piping) shorten the slings at one end so the casing is approximately horizontal.

# Rigging method lower section

## RIGGING METHOD A

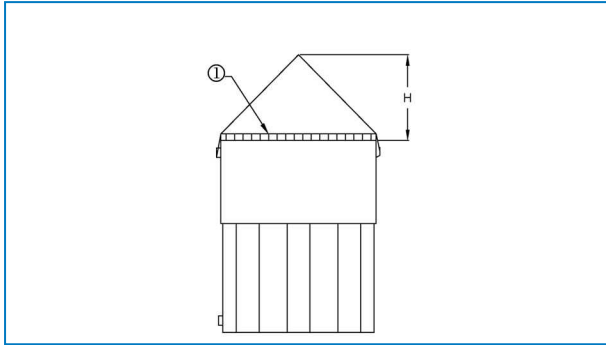

1. Spreader. Safety slings recommended

## RIGGING METHOD B

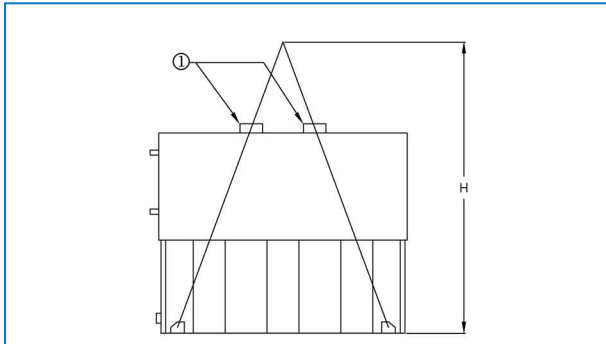

1. Spreader

## RIGGING METHOD C

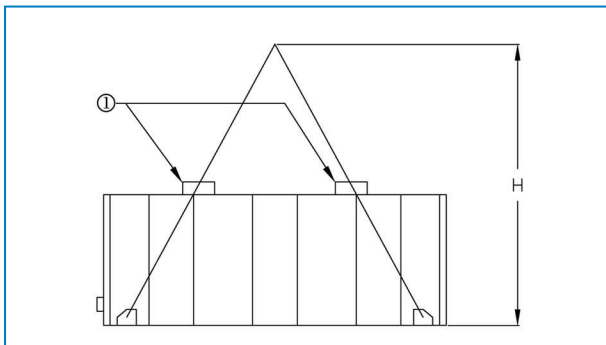

1. Spreader



## RIGGING METHOD D

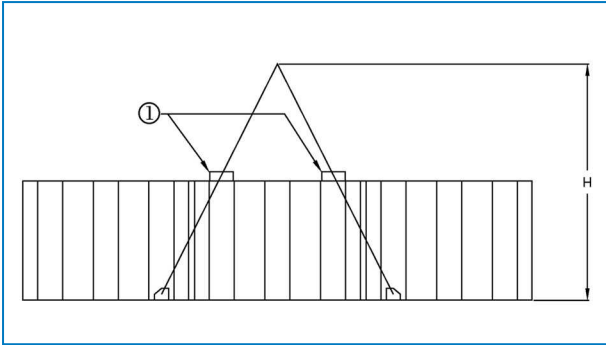

1. Spreader. Safety slings recommended

## Rigging method upper section

### RIGGING METHOD G - COIL PRODUCTS AND DISCHARGE ACCESSORIES

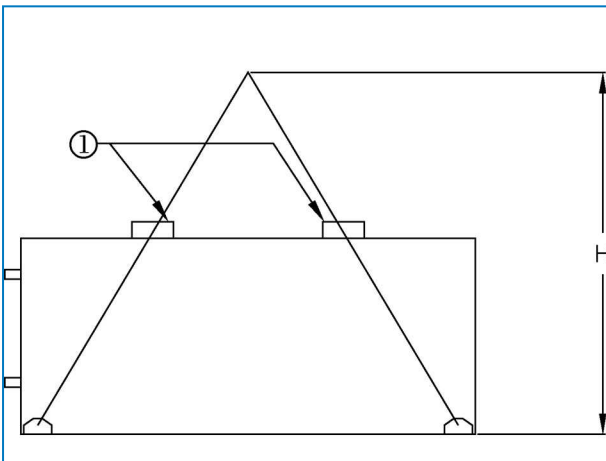

1. Spreader

### RIGGING METHOD H - COIL PRODUCTS AND DISCHARGE ACCESSORIES

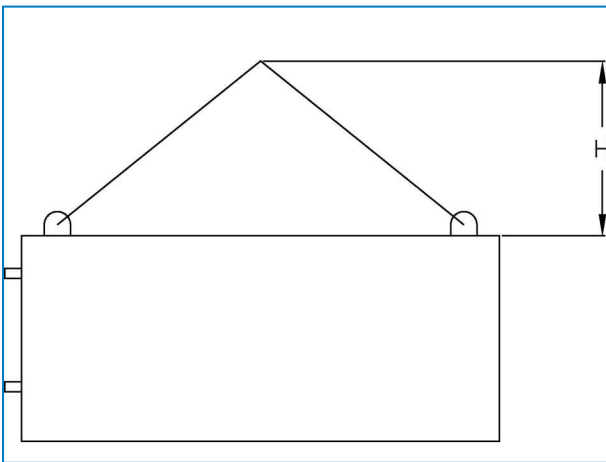

## Method

1. Position the lower section on the supporting steel and bolt in place.
2. Remove any protective wood from the top horizontal flanges of the lower section. Wipe down the flanges to remove dust, dirt or moisture that may have accumulated during shipment and storage.
3. Apply the 25 mm wide tape sealer around the periphery of the top flange of the lower section.  
This tape sealer must be centred directly over the centreline of the taper holes and on the centreline of the end flanges where there are no taper holes. The sealer is to be spliced only along the flanges with taper holes. When it is necessary to splice sealer, mitre and press the two ends together so as to form a smooth, continuous bead. Tape sealer is trapezoidal in shape and must be installed wide side down (see figure "Installation of tape sealer"). Do not stretch sealer tape.
4. Refer to the unit tables (See "Rigging"General notes" on page 13

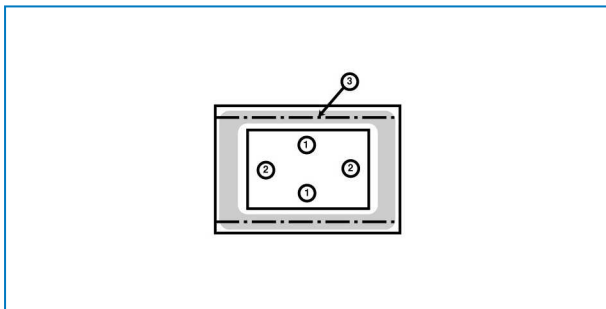

Sealing method I

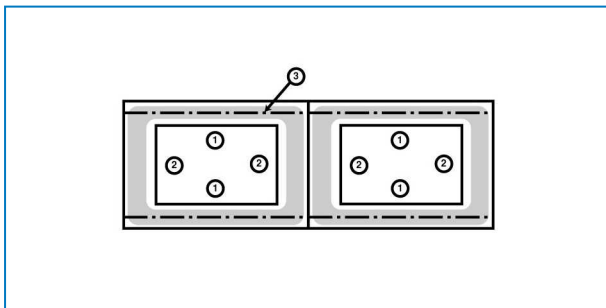

Sealing method J

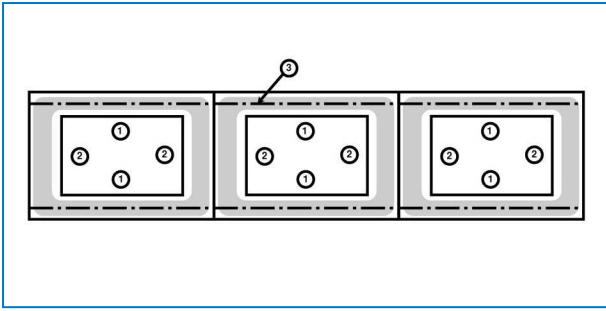

*Sealing method K*

1. Apply 25 mm flat tape sealer over centreline of screw holes.
  2. Apply 25 mm flat tape sealer over centreline of cross flanges.
  3. Screw hole centreline.
5. Sealer applied to the end flanges of a single cell section unit and to the end and centre flanges of two cell units must be continuous.

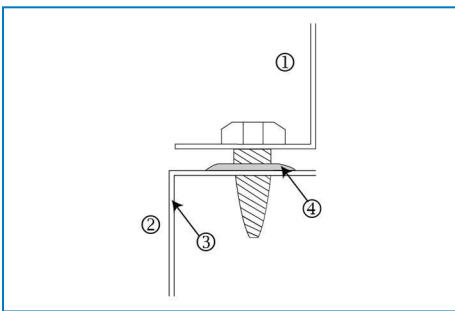

*Installation of tape sealer*

1. Upper section
2. Lower section
3. Lower section frame
4. 25 mm flat tape sealer laid over punch line wide side down.

When rigging the casing sections one might consider to hang the casing under a small angle (1-2°) in the crane. This way one short end can be positioned first and then the rest of the casing can be lowered slowly.

 Once the casing is put on the sealer tape, it can not be moved any more so gentle positioning is required.

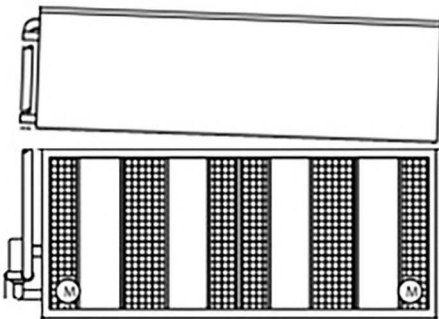

*Position the casing at an angle.*

For units with double casing, make sure the section with the splice plate with the lip at the bottom is installed first. The other section has a lip at the top of the splice plate.



1. Lip at the bottom of the splice plate.
2. Lip at the top of the splice plate

6. Remove the skid from the middle section. Lift the middle section and position it over the lower section so that the flanges of the section are about 50 mm above the lower section. Do not let the section swing and damage the sealer.

Use at least four drift pins (see figure) in the fastening holes located on the long sides of the sections to align the top section to the bottom section. To avoid incorrect alignment, refer to the below drawing for the position of the fastening holes to be used. Use additional drift pins in the middle of the unit if required, to align long panels. (See figure "Usage of drift pin to align the screw holes")

Make sure all holes from upper section and lower section are properly aligned before lowering the top section completely to the bottom section.

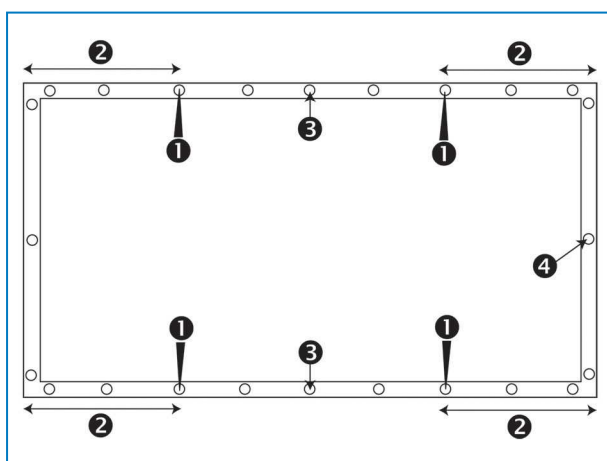

Position of the fastening holes to be used.

1. Drift pin position
2. The distance between the fastening hole in which the drift pin is inserted and the corner should be at least 30cm
3. Usage of additional drift pin for long sides
4. Fastening hole



**CAUTION**

**When lowering a section, ensure nothing can be trapped between the upper and lower flanges.**

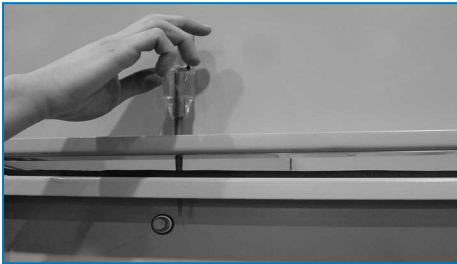

*Usage of drift pin to align the screw holes*

7. Using the self-tapping screws, drive screws down through the middle section and into the lower section. Start next to lifting ear towards centre of unit. Continue to install the screws using the drift pin to align the screw holes until all holes are filled with screws
8. Secure the flexible hose that connects the upper and lower sections of the pump discharge pipe using the hose clamps provided.
9. Remove any wooden or plastic bracing from around the eliminators or upper section(s).
10. Remove shipping straps after rigging.



*Shipping straps*

1. Shipping straps

## General

1. All required installation instructions for optional accessories are stored in the wooden no nail crate / plastic container which is placed in the lower section. See "Inspection Before Rigging" on page 1 - picture "Hardware Location".
2. Optional discharge accessories such as tapered hoods, positive closure dampers, discharge sound attenuators, desuperheaters, plume abatement coils and/or access plenums can be fitted.
3. Refer to the unit certified drawing for installation sequence of optional accessories.
4. Sealing methods are the same as for the upper section.
5. Rigging method of optional accessories is indicated in the rigging tables.(see "General notes" on page 13)



### CAUTION

**Make sure coupling is installed on external piping if delivered with the dry coil.**

6. The platform, ladder and railing is packed on a separate skid. The assembly hardware is packed in a plastic container and strapped to the platform, ladder or railing itself.



*Hardware location for platform, ladder & railing*

# Placement of Steel Eliminators

Only for containerized models or steel eliminator option.

Check the placement of the steel eliminator sections on the top of the unit against the placement listed in the Rigging methods tables. The eliminator sections are match marked to aid in their correct placement.

## INSTALLATION METHOD L

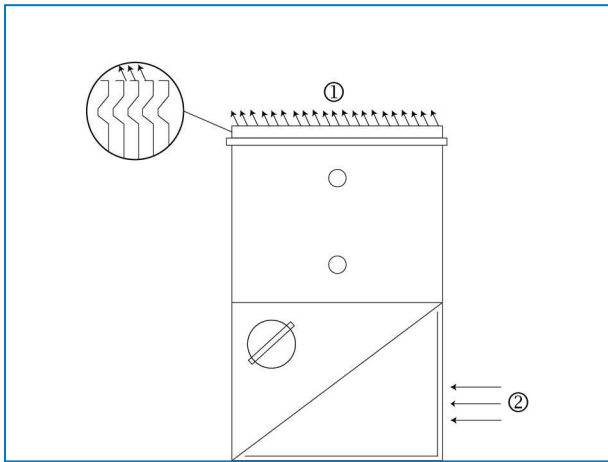

1. Air discharge
2. Air inlet

## INSTALLATION METHOD M

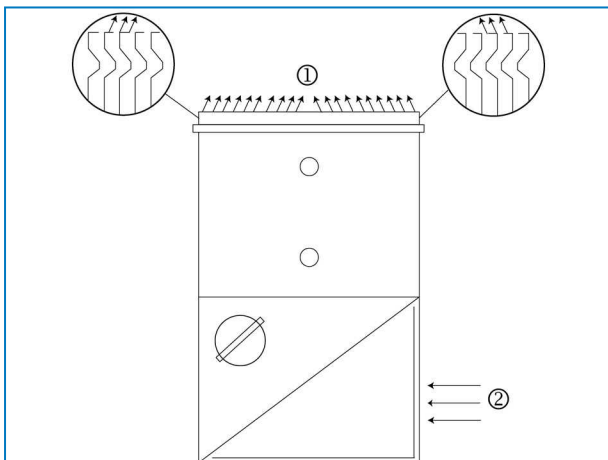

1. Air discharge
2. Air inlet

## Clean out port

Due to transport width limits, the cover flanges of the clean out port are mounted with flanges towards the inside (1). On site, the cover can be placed with flanges to the outside for easy access to hardware (2).

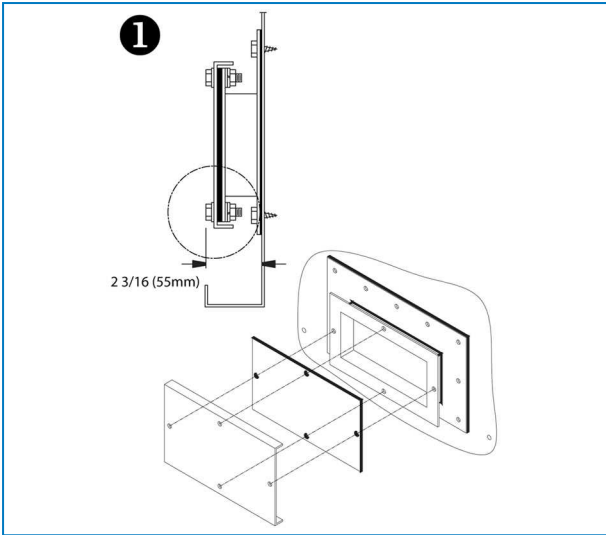

*Clean out port cover mounted for transport*

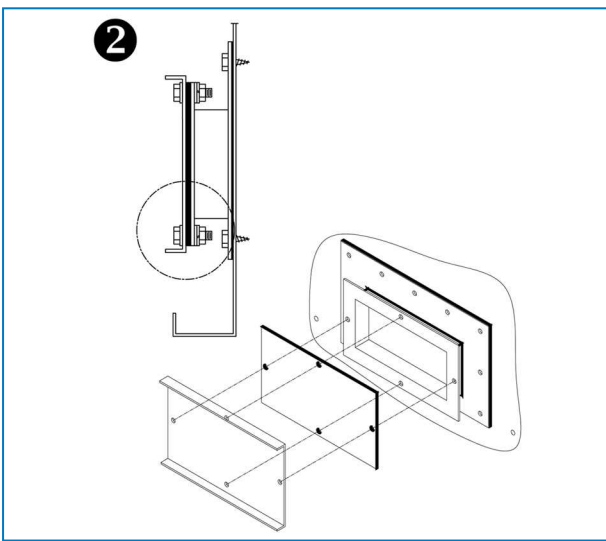

*Final installation of clean out port cover*





VXC

## INSPECTION PRIOR TO START-UP

### General

Prior to start-up, the following services, which are described in detail in the Operating and Maintenance Manual (see table "Recommended maintenance and monitoring programme" ) must be performed.

Proper start-up procedures and scheduled periodic maintenance will prolong the life of the equipment and ensure trouble-free performance for which the unit is designed.

## Assistance

BAC has established a specialized total care company called Balticare. The BAC Balticare offering involves all elements required to ensure a safe and efficient operation of your evaporative cooling products.

For more details, contact your local BAC representative for further information and specific assistance at [www.BaltimoreAircoil.eu](http://www.BaltimoreAircoil.eu)

## More information

### REFERENCE LITERATURE

- Eurovent 9-5 (6) Recommended Code of Practice to keep your Cooling System efficient and safe. Eurovent/Cecomaf, 2002, 30p.
- Guide des Bonnes Pratiques, Legionella et Tours Aéroréfrigérantes. Ministères de l'Emploi et de la Solidarité, Ministère de l'Economie des Finances et de l'Industrie, Ministère de l'Environnement, Juin 2001, 54p.
- Voorkom Legionellose. Ministerie van de Vlaamse Gemeenschap. December 2002, 77p.
- Legionnaires' Disease. The Control of Legionella Bacteria in Water Systems. Health & Safety Commission. 2000, 62p.
- Hygienische Anforderungen an raumluftechnische Anlagen. VDI 6022.

### INTERESTING WEBSITES

- [www.BaltimoreAircoil.eu](http://www.BaltimoreAircoil.eu)
- [www.eurovent-certification.com](http://www.eurovent-certification.com)
- [www.ewgli.org](http://www.ewgli.org)
- [www.ashrae.org](http://www.ashrae.org)
- [www.uniclima.org](http://www.uniclima.org)
- [www.aicvf.org](http://www.aicvf.org)
- [www.hse.gov.uk](http://www.hse.gov.uk)

### ORIGINAL DOCUMENTATION



This manual is originally made in English. Translations are provided for your convenience. In the event of discrepancies, the English original text shall prevail over the translation.



A series of horizontal dotted lines for writing, spanning the width of the page.



A series of horizontal dotted lines for writing, spanning the width of the page.





A series of horizontal dotted lines for writing, spanning the width of the page.

COOLING TOWERS

---

CLOSED CIRCUIT COOLING TOWERS

---

ICE THERMAL STORAGE

---

EVAPORATIVE CONDENSERS

---

HYBRID PRODUCTS

---

PARTS, EQUIPMENTS & SERVICES

BLUE by nature  
GREEN at heart



[www.BaltimoreAircoil.eu](http://www.BaltimoreAircoil.eu)

[info@BaltimoreAircoil.eu](mailto:info@BaltimoreAircoil.eu)

Please refer to our website for local contact details.

Industriepark - Zone A, B-2220 Heist-op-den-Berg, Belgium

© Baltimore Aircoil International nv